

NEW



GENESYSTM GH1kW/1.5kW Series Programmable DC Power Supplies Half-Rack 1kW/1.5kW in 1U Height

! Advanced Features Built-In !

- *Arbitrary Waveform Generator with Auto-Trigger Capability*
 - *Programmable Slew Rate Control (Vout/Iout)*
- *Constant Power Limit Operation • Internal Resistance Programming*
 - *Built-In Remote Isolated Analog Interface*
- *Built-In LAN (LXI 1.5), USB, and RS-232/RS-485 Interfaces*
- *Optional EtherCAT, Modbus-TCP, IEEE (488.2) Interfaces*
 - *Blank Front Panel Option Available*



TDK-Lambda
Innovating Reliable Power
www.emea.lambda.tdk.com

The **GENESYS™** family of programmable power supplies sets a new standard for flexible, reliable, AC/DC power systems in OEM, Industrial and Laboratory applications.

Features include:

- Leading DC Programmable power density (1.5kW in 1U height) in 19" Half-Rack-mount
- Light-weight <3.5 kg
- Wide Range of popular worldwide AC inputs:
GH1kW/1.5kW: 1Ø (85~265VAC)
- Active PFC (0.99 typical)
- Output Voltage up to 600V, Current up to 150A
- Built-in LAN (*LXI* 1.5), USB, RS-232/RS-485 Interface
- Multi-Drop capability (RS-485)
- Multi-functional front panel display
- Last-Setting Memory
- Auto-Start / Safe-Start: user selectable
- High Resolution 16 bit ADCs & DACs
- Arbitrary Waveform Generator with Auto-Trigger Capability
- Store up to 100 steps into four internal memory cells
- High-speed Programming
- Constant Voltage/Constant Current operation modes
- Constant Power (CP) Limit
- Slew-Rate Control (V/I)
- Internal Resistance Programming Simulation
- Local / Remote Sensing - software controlled
- Built-In Remote Isolated Analog Program/Monitor and Control Interface
- Protection functions (OVP, UVP, UVL, FOLD (CV/CC), OCL, OTP, AC FAIL)
- Fan speed profile controlled by ambient temperature and load
- Certified LabWindows™/CVI, LabVIEW™, and IMI Drivers
- Optional EtherCAT, Modbus-TCP, IEEE (488.2) Interfaces
- 19" Rack Mount capability for ATE and OEM application
- Scalable Power Systems
- Parallel Systems with Auto-Configure
- Worldwide Safety Agency approvals
- CE Mark for Low Voltage, EMC and RoHS3 Directives
- Five year warranty

Applications

GENESYS™ power supplies have been designed to meet the demands of a wide variety of applications.

Test & Measurement systems, Component Device Testing, Manufacturing and process control.

Semiconductor Processing & Burn-In, Aerospace & Satellite Testing, Medical Imaging, Green Technology.

Higher power systems can be configured with up to four 1.5kW units.
Each unit is 1U with zero space between them (zero stack).

OEM Designers have a wide variety of Inputs and Outputs from which to select depending on application and location.

GH1kW/1.5kW Front Panel Description



- 1. Input Power ON/OFF Switch
- 2. Air Intake allows zero stacking for maximum system flexibility and power density.
- 3. Reliable Detent Encoders for settings and Menu navigation.
- 4. High Contrast/Brightness display with wide viewing angle, 16 segment LCD
- 5. Function/Status LEDs: Active modes and function indicators
- 6. Pushbuttons allow flexible user configuration

GH1kW/1.5kW Rear Panel Description

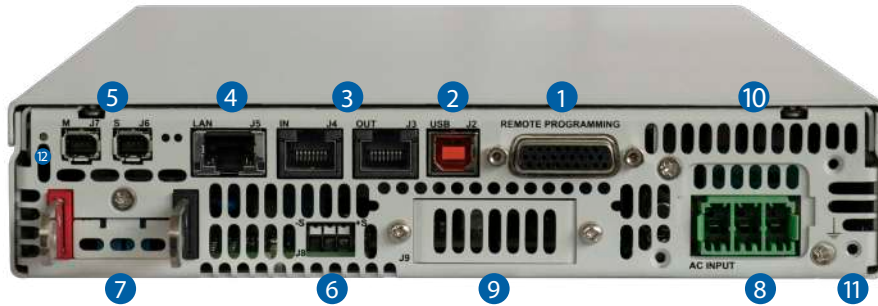

- 1. Isolated Analog Programming, Monitoring and other control connector (DB26 Female)
- 2. USB Interface connector (Type B).
- 3. RS-232/RS-485 IN/OUT Remote Digital Interface (RJ-45 type) for Multi-Drop connection
- 4. LAN (LXI 1.5) Interface connector (RJ-45 type with LAN status indicators).
- 5. Auto paralleling Bus connectors (mini I/O type) for connecting Master unit-to-Slave and Slave unit-to-Slave unit.
- 6. Remote/Local Output Voltage Sense Connections (spring cage).
- 7. Output Connections: Rugged busbars (shown) for models up to and including 100V Output; Output connector: PHOENIX CONTACT GIC 2.5/4-G-7,62 for models with Outputs >100V. Plug connector: PHOENIX CONTACT GIC 2.5/4-ST-7,62 for models with Outputs >100V.
- 8. GH1.5kW Input: 85~265VAC, Single Phase, 50/60 Hz.
AC Input Connector: PHOENIX CONTACT Power Combicon PC 5/3-G-7,62
AC Input Plug Connector: PHOENIX CONTACT Power Combicon PC 5/3-STCL1-7,62 Series with strain relief. (Model shown) GH1kW AC Input Connector: IEC320 C16.
- 9. Optional Interface Position for IEEE 488.2 SCPI or AnyBus Interface.
- 10. Exhaust air assures reliable operation when units are zero stacked.
- 11. Functional Ground connection (M3x8mm screw).
- 12. Reset button. Set default Power Supply settings.

Front Panel Display MENU/CONTROL buttons:

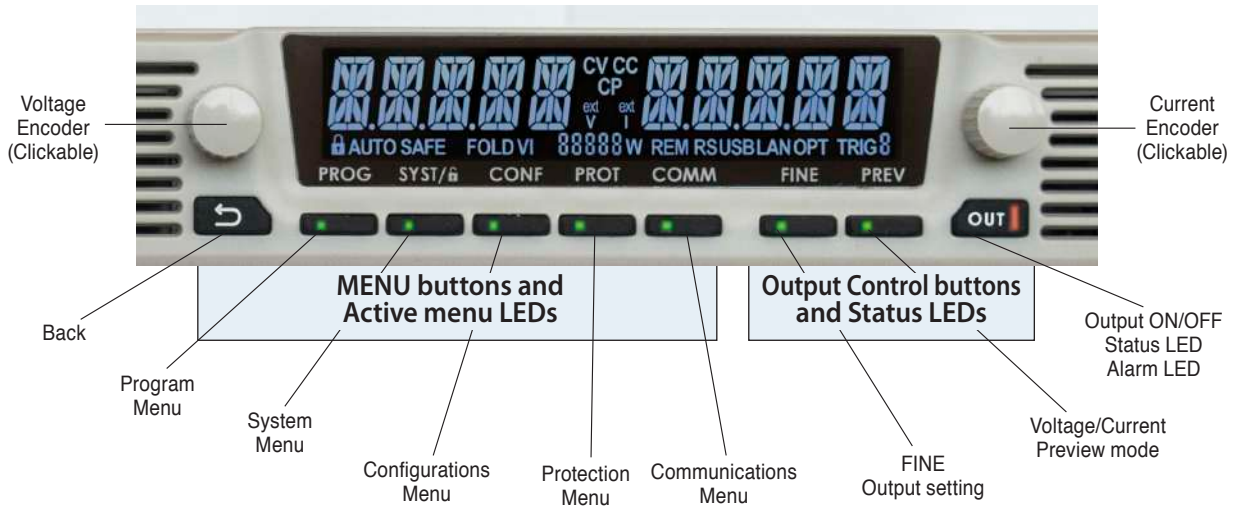

Front Panel Display indicators

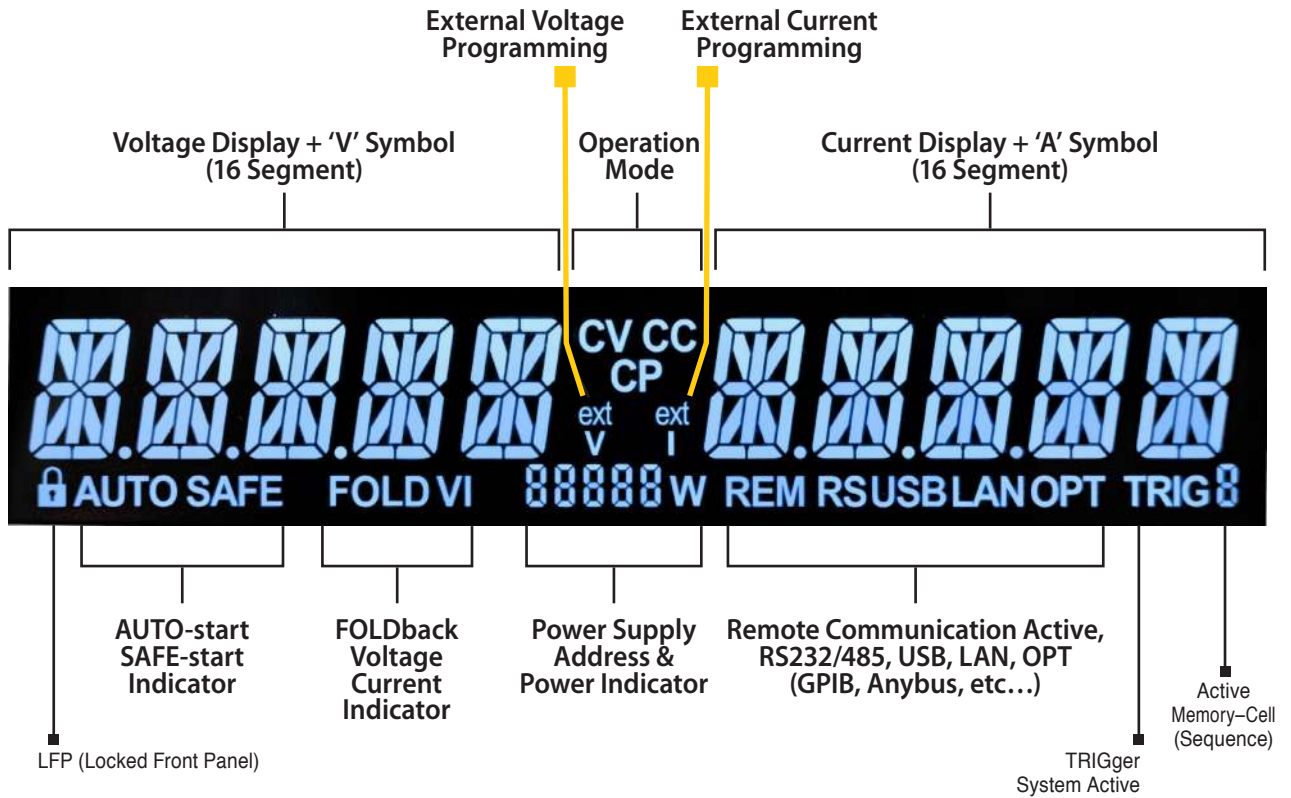

GENESYS™ GHB1kW/1.5kW Series
Blank Front Panel (ATE version)



A Blank Front Panel is available for applications where the front panel display and controls are not required and only remote interface (Digital/Analog) is needed. The Blank Front Panel option has all the standard product functions and features except the display. The power supply can be controlled via the rear panel Remote Digital Interface (LAN, USB, RS-232/RS-485) or via the Remote Isolated Analog Interface.

GENESYS™ Parallel and Series Configurations

Parallel operation - Master/Slave:

Auto paralleling Scalable Master-Slave Operation. Active current sharing allows up to four identical units to be connected. Total real current is programmed, measured and reported by the Master. Up to four supplies operate as one.

Standard Unit - zero stacked up to 4 units



Series operation

Two units may be connected in series to increase the output voltage or to provide bipolar output. (Max 600V to Chassis Ground).

Multi-Drop Remote Programming via Communication Interface

Standard Built-in LAN, USB, RS-232 & RS-485 allows "Multi-Drop" daisy-chain control of up to 31 Power supplies on the same communication bus. Can be daisy chained via built-in RS-485 Interface.

- First unit is LAN, USB, RS-232, RS-485, etc.
- All other units use RS-485 daisy chain with linking cable.



LAN, USB, RS-232, RS-485, IEEE, AnyBus

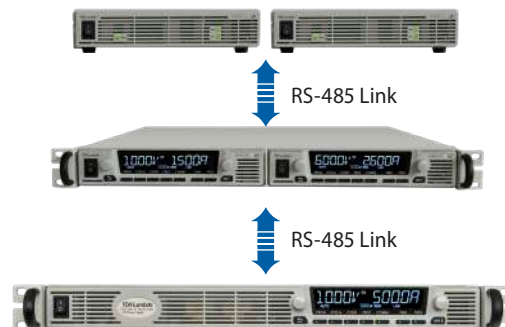

Graphical User Interface

Advanced "Virtual Front Panel" allows programming and monitoring unit(s) with or without front panel display.

1. Control and monitor up-to 31 units with "Address" bar
2. Front panel set-up menu control (PROGram, SYSTem, CONFIguration, PROTection and COMMunication)
3. Informative "Parameters" status bar
4. Individual unit and Global command control
5. Data logging including errors, events and recovery
6. Realtime Graph and Waveform creator, store/load sequence.
7. Solar array mode - calculate MPP (Max Peak Power) for solar array.
8. Registers View: Operation Status, Fault, Event Status, ENABLE and INTERLOCK signals.
9. Remote communication state LOC, REM, LLO.
10. Programmed signals 1&2

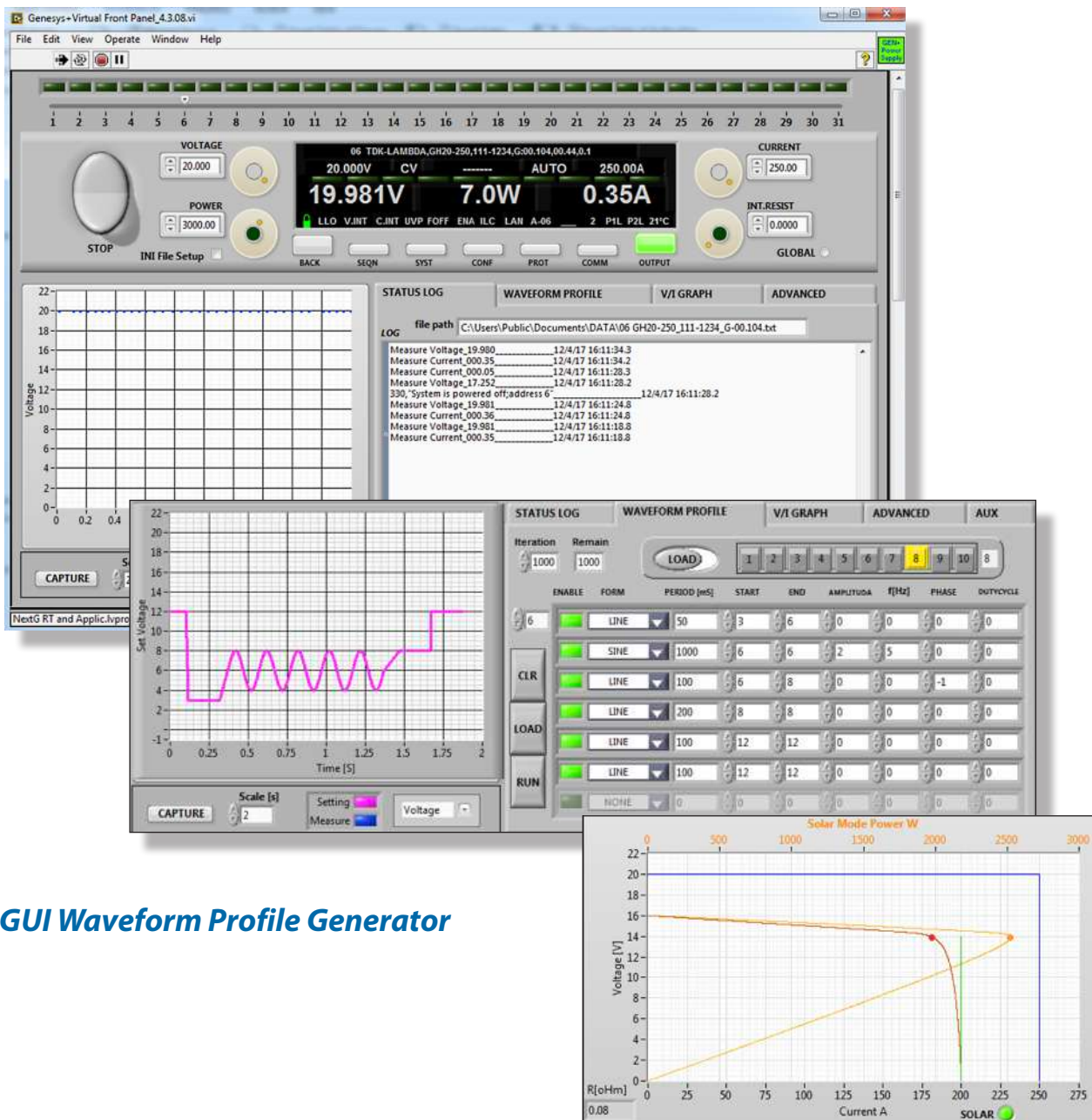

GUI Waveform Profile Generator

How to order GH1kW/1.5kW - Power Supply Identification / Accessories

GH	10	150			
Series Name	Output	Output	Interface Options	AC Cord Options only for 1kW	Accessories Options
Front Panel Type	Voltage	Current		Region: E - Europe	M - Printed *User Manual
Empty: standard	(0~10V)	(0~150A)		U - North America	* User Manual & GUI are available on the website
B: Blank Front Panel				J - Japan	P - Bus Parralleling Cable
				C - China	
				I - Middle East	

AC Inputs (All Models)

1Ø, 85 ~ 265Vac

Interface Options (Factory installed)

- LAN (✓) 1.5 compliant with Multi-Drop capability)- built-in
- USB 2.0 compliant with Multi-Drop capability - built-in
- RS-232/RS-485 - built-in
- Isolated Analog Program/Monitor Interface (5V/10V Pgm/Mon with 600V isolation) - built-in
- IEEE (488.2 & SCPI compliant with Multi-Drop capability installed)
- Modbus-TCP
- EtherCAT

P/N

-
-
-
-
- IEEE
- MDBS
- ECAT

Models 1kW

Model	Voltage (V)	Current (A)	Power (W)
GH10-100	0~10V	0~100	1000
GH20-50	0~20V	0~50	1000
GH30-34	0~30V	0~34	1020
GH40-25	0~40V	0~25	1000
GH60-17	0~60V	0~17	1020

Model	Voltage (V)	Current (A)	Power (W)
GH80-12.5	0~80V	0~12.5	1000
GH100-10	0~100V	0~10	1000
GH150-7	0~150V	0~7	1050
GH300-3.5	0~300V	0~3.5	1050
GH600-1.7	0~600V	0~1.7	1020

Models 1.5kW

Model	Voltage (V)	Current (A)	Power (W)
GH10-150	0~10V	0~150	1500
GH20-75	0~20V	0~75	1500
GH30-50	0~30V	0~50	1500
GH40-38	0~40V	0~38	1520
GH60-25	0~60V	0~25	1500

Model	Voltage (V)	Current (A)	Power (W)
GH80-19	0~80V	0~19	1520
GH100-15	0~100V	0~15	1500
GH150-10	0~150V	0~10	1500
GH300-5	0~300V	0~5	1500
GH600-2.6	0~600V	0~2.6	1560

Accessories

Rack Mounting applications P/N:GH/RM

The Rack Mounted kit allows the units to be zero stacking for maximum system flexibility and power density without increasing the 1U height of the units To install one GH1kW/1.5kW unit or two units side-by-side in a standard 19" rack in 1U(1.75") height, use option kit P/N:GH/RM

Single unit installation

Single GH1kW/1.5kW power supply in a standard 19" rack in 1U(1.75") height

Dual unit installation

Two GH1kW/1.5kW power supplies side-by-side in a standard 19" rack in 1U (1.75") height



Benchtop applications Multi Output P/N:GH/MO

The benchtop stacking kit allows the units to be Zero stacked for maximum system flexibility and power density without increasing the 1U height of the units.

To install a GH1kW/1.5kW two units one on top of the other use option kit P/N:GH/MO-2U



GENESYS™ GH1kW SERIES SPECIFICATIONS

OUTPUT RATING		GH	10-100	20-50	30-34	40-25	60-17	80-19	100-10	150-7	300-3.5	600-1.7	
1. Rated output voltage (*1)		V	10	20	30	40	60	80	100	150	300	600	
2. Rated output current (*2)		A	100	50	34	25	17	12.5	10	7	3.5	1.7	
3. Rated output power		W	1000	1000	1020	1000	1020	1000	1000	1050	1050	1020	
INPUT CHARACTERISTICS		V	10	20	30	40	60	80	100	150	300	600	
1. Input voltage/freq. (*3)		---	85~265Vac, continuous, 47~63Hz, Single Phase										
2. Maximum Input current at 100% load (100/200)		A	12.5/6.5										
3. Power Factor (Typ)		---	0.99 @ 100Vac 0.98 @ 200Vac, rated output power.										
4. Efficiency at 100 Vac/200Vac, rated output (*17)		%	86/88	87/89	87/89	87/89	87/89	87/89	88/90	88/90	88/90	88/90	
5. Inrush current (*5)		A	Less than 50A										
CONSTANT VOLTAGE MODE		V	10	20	30	40	60	80	100	150	300	600	
1. Max. Line regulation (*6)		---	0.01% of rated output voltage										
2. Max. Load regulation (*7)		---	0.01% of rated output voltage +2mV										
3. Ripple and noise (p-p, 20MHz) (*8)		mV	50	50	50	60	60	75	75	75	200	500	
4. Ripple r.m.s. 5Hz~1MHz (*8)		mV	6	6	6	7	7	10	20	20	50	100	
5. Temperature coefficient		PPM/°C	50PPM/°C from rated output voltage, following 30 minutes warm-up.										
6. Temperature stability		---	0.01% of rated Vout over 8hrs interval following 30 minutes warm-up. Constant line, load & temp.										
7. Warm-up drift		---	Less than 0.01% of rated output voltage+2mV over 30 minutes following power on.										
8. Remote sense compensation/wire (*10)		V	2	2	5	5	5	5	5	5	5	5	
9. Up-prog. Response time (*11)		mS	35	35	35	35	35	35	40	50	100	100	
10. Down-prog. response time:		Full load (*12)	mS	30	30	60	60	60	60	80	120	220	220
		No load (*12)	mS	500	700	900	1200	1500	1700	2000	2500	3300	3500
11. Transient response time		mS	Time for output voltage to recover within 0.5% of its rated output for a load change 10~90% of rated output current. Output set-point: 10~100%, Local sense. Less than 1.5mS, for 10V models. Less than 1mS, for models up to and including 100V. 2mS for models above 100V.										
12. Start up delay		Sec	Less than 6 Sec										
13. Hold-up time		mS	20ms typical, rated output power										
CONSTANT CURRENT MODE		V	10	20	30	40	60	80	100	150	300	600	
1. Max. Line regulation (*6)		---	0.01% of rated output current. +2mA										
2. Max. Load regulation (*9)		---	0.02% of rated output current. +5mA										
3. Ripple r.m.s. @ rated voltage. B.W 5Hz~1MHz. (*13)		mA	≤420	≤160	≤100	≤60	≤50	≤30	≤20	≤10	≤8	≤5	
5. Temperature coefficient		PPM/°C	10V~100V 100PPM/°C from rated output current, following 30 minutes warm-up. 150V~600V 70PPM/°C from rated output current, following 30 minutes warm-up.										
6. Temperature stability		---	0.02% of rated Iout over 8hrs. interval following 30 minutes warm-up. Constant line, load & temperature.										
7. Warm-up drift		---	10V~100V model: Less than +/-0.25% of rated output current over 30 minutes following power on. 150V~600V: Less than +/-0.15% of rated output current over 30 minutes following power on.										
ANALOG PROGRAMMING AND MONITORING (ISOLATED FROM THE OUTPUT)													
1. Vout voltage programming		---	0~100%, 0~5V or 0~10V, user selectable. Accuracy and linearity: +/-0.15% of rated Vout.										
2. Iout voltage programming (*14)		---	0~100%, 0~5V or 0~10V, user selectable. Accuracy and linearity: +/-0.4% of rated Iout.										
3. Vout resistor programming		---	0~100%, 0~5/10Kohm full scale, user selectable. Accuracy and linearity: +/-0.5% of rated Vout.										
4. Iout resistor programming (*14)		---	0~100%, 0~5/10Kohm full scale, user selectable. Accuracy and linearity: +/-0.5% of rated Iout.										
5. Output voltage monitor		---	0~5V or 0~10V, user selectable. Accuracy: +/-0.5% of rated Vout.										
6. Output current monitor (*14)		---	0~5V or 0~10V, user selectable. Accuracy: +/-0.5% of rated Iout.										
SIGNALS AND CONTROLS (ISOLATED FROM THE OUTPUT)													
1. Power supply OK #1 signal		---	Power supply output monitor. Open collector. Output On: On. Output Off: Off. Maximum Voltage: 30V, Maximum Sink Current: 10mA.										
2. CV/CC signal		---	CV/CC Monitor. Open collector. CC mode: On. CV mode: Off. Maximum Voltage: 30V, Maximum Sink Current: 10mA.										
3. LOCAL/REMOTE Analog control		---	Enable/Disable analog programming control by electrical signal or dry contact. Remote: 0~0.6V or short. Local: 2~30V or open.										
4. LOCAL/REMOTE Analog signal		---	analog programming control monitor signal. Open collector. Remote: On. Local: Off. Maximum Voltage: 30V, Maximum Sink Current: 10mA.										
5. ENABLE/DISABLE signal		---	Enable/Disable PS output by electrical signal or dry contact. 0~0.6V or short, 2~30V or open. User selectable logic.										
6. INTERLOCK (ILC) control		---	Enable/Disable PS output by electrical signal or dry contact. Remote: 0~0.6V or short. Local: 2~30V or open.										
7. Programmed signals		---	Two open drain programmable signals. Maximum voltage 25V, Maximum sink current 100mA (Shunted by 27V zener)										
8. TRIGGER IN / TRIGGER OUT signals		---	Maximum low level input voltage = 0.8V, Minimum high level input voltage = 2.5V, Maximum high level input = 5V positive edge trigger: tw=10us minimum. Tr, Tf=1us Maximum, Min delay between 2 pulses 1ms.										
9. DAISY_IN/SO control signal		---	By electrical Voltage: 0~0.6V/2~30V or dry contact.										
10. DAISY_OUT/PS_OK #2 signal		---	4~5V=OK, 0V (500ohm impedance)=Fail										
FUNCTIONS AND FEATURES													
1. Parallel operation		---	Possible. Up to 4 identical units in Master/Slave mode. Refer to instruction manual.										
2. Series operation		---	Possible. Two identical units. Refer to instruction manual.										
3. Daisy chain		---	Power supplies can be connected in Daisy chain to synchronize their turn-on and turn-off.										
4. Constant power control		---	Limits the output power to a programmed value. Programming via the communication ports or the front panel.										
5. Output resistance control		---	Emulates series resistance. Resistance range: 1~1000mΩ. Programming via the communication ports or the front panel.										
6. Slew rate control		---	Programmable Output rise and Output fall slew rate. Programming range: 0.0001~999.99 V/mSec. or A/mSec. Programming via the communication ports or the front panel.										
7. Arbitrary waveforms		---	Profiles of up to 100 steps can be stored in 4 memory cells. Activation by command via the communication ports or by the front panel.										
PROGRAMMING AND READBACK (USB, LAN, RS232/485, Optional IEEE (*16) Interfaces)		V	10	20	30	40	60	80	100	150	300	600	
1. Vout programming accuracy (*15)		---	0.05% of rated output voltage										
2. Iout programming accuracy (*14)		---	0.1% of actual output current+0.2% of rated output current										
3. Vout programming resolution		---	0.002% of rated output voltage										
4. Iout programming resolution		---	0.0025% of rated output current										
5. Vout readback accuracy		---	0.05% of rated output voltage										
6. Iout readback accuracy (*14)		---	0.2% of rated output current										
7. Vout readback resolution (of rated output voltage)		%	0.011%	0.006%	0.004%	0.003%	0.002%	0.002%	0.011%	0.007%	0.004%	0.002%	
8. Iout readback resolution (of rated output current)		%	0.011%	0.003%	0.004%	0.005%	0.007%	0.009%	0.011%	0.015%	0.004%	0.007%	

GENESYS™ GH1.5kW SERIES SPECIFICATIONS

OUTPUT RATING		GH	10-150	20-75	30-50	40-38	60-25	80-19	100-15	150-10	300-5	600-2.6
1.Rated output voltage(*1)		V	10	20	30	40	60	80	100	150	300	600
2.Rated output current (*2)		A	150	75	50	38	25	19	15	10	5	2.6
3.Rated output power		W	1500	1500	1500	1520	1500	1520	1500	1500	1500	1560
INPUT CHARACTERISTICS		V	10	20	30	40	60	80	100	150	300	600
1.Input voltage/freq. (*3)		---	85~265Vac, continuous, 47~63Hz, Single Phase									
2. Maximum Input current at 100% load (100/200)		A	18.5/9									
3.Power Factor (Typ)		---	0.99 @ 100Vac 0.98 @ 200Vac, rated output power.									
4.Efficiency at 100 Vac/200Vac, rated output (*19)		%	86/88	87/89	87/89	87/89	87/89	87/89	88/90	88/90	88/90	88/90
5.Inrush current (*5)		A	Less than 50A									
CONSTANT VOLTAGE MODE		V	10	20	30	40	60	80	100	150	300	600
1.Max. Line regulation (*6)		---	0.01% of rated output voltage									
2.Max. Load regulation (*7)		---	0.01% of rated output voltage +2mV									
3.Ripple and noise (p-p, 20MHz) (*8)		mV	50	50	50	60	60	75	130	75	180	500
4.Ripple r.m.s. 5Hz~1MHz (*8)		mV	6	6	6	7	7	8	30	20	45	100
5.Temperature coefficient		PPM/°C	50PPM/°C from rated output voltage, following 30 minutes warm-up.									
6.Temperature stability		---	0.01% of rated Vout over 8hrs interval following 30 minutes warm-up. Constant line, load & temp.									
7. Warm-up drift		---	Less than 0.01% of rated output voltage+2mV over 30 minutes following power on.									
8.Remote sense compensation/wire (*10)		V	2	2	5	5	5	5	5	5	5	5
9.Up-prog. Response time (*11)		mS	20	20	20	20	20	20	20	30	30	40
10.Down-prog.response time:		Full load (*12)	mS	20	20	20	30	30	50	60	70	80
		No load (*12)	mS	300	500	600	900	1200	1300	1700	2200	2700
11.Transient response time		mS	Time for output voltage to recover within 0.5% of its rated output for a load change 10~90% of rated output current. Output set-point: 10~100%, Local sense. Less than 1mS, for models up to and including 100V. 2mS, for models above 100V.									
12.Start up delay		Sec	Less than 6 Sec									
13.Hold-up time		mS	20ms typical, rated output power									
CONSTANT CURRENT MODE		V	10	20	30	40	60	80	100	150	300	600
1.Max. Line regulation (*6)		---	0.01% of rated output current. +2mA									
2.Max. Load regulation (*9)		---	0.02% of rated output current. +5mA									
3.Ripple r.m.s. @ rated voltage. B.W 5Hz~1MHz. (*13)		mA	≤250	≤130	≤100	≤60	≤50	≤30	≤40	≤10	≤8	≤5
5.Temperature coefficient		PPM/°C	10V~100V 100PPM/°C from rated output current, following 30 minutes warm-up. 150V~600V 70PPM/°C from rated output current, following 30 minutes warm-up.									
6.Temperature stability		---	0.01% of rated Iout over 8hrs. interval following 30 minutes warm-up. Constant line, load & temperature.									
7. Warm-up drift		---	10V~100V model: Less than +/-0.25% of rated output current over 30 minutes following power on. 150V~600V: Less than +/-0.15% of rated output current over 30 minutes following power on.									
ANALOG PROGRAMMING AND MONITORING (ISOLATED FROM THE OUTPUT)												
1.Vout voltage programming		---	0~100%, 0~5V or 0~10V, user selectable. Accuracy and linearity: +/-0.15% of rated Vout.									
2.Iout voltage programming (*14)		---	0~100%, 0~5V or 0~10V, user selectable. Accuracy and linearity: +/-0.4% of rated Iout.									
3.Vout resistor programming		---	0~100%, 0~5/10Kohm full scale, user selectable. Accuracy and linearity: +/-0.5% of rated Vout.									
4.Iout resistor programming (*14)		---	0~100%, 0~5/10Kohm full scale, user selectable. Accuracy and linearity: +/-0.5% of rated Iout.									
5.Output voltage monitor		---	0~5V or 0~10V, user selectable. Accuracy: +/-0.5% of rated Vout.									
6.Output current monitor (*14)		---	0~5V or 0~10V, user selectable. Accuracy: +/-0.5% of rated Iout.									
SIGNALS AND CONTROLS (ISOLATED FROM THE OUTPUT)												
1. Power supply OK #1 signal		---	Power supply output monitor. Open collector. Output On: On. Output Off: Off. Maximum Voltage: 30V, Maximum Sink Current: 10mA.									
2. CV/CC signal		---	CV/CC Monitor. Open collector. CC mode: On. CV mode: Off. Maximum Voltage: 30V, Maximum Sink Current: 10mA.									
3. LOCAL/REMOTE Analog control		---	Enable/Disable analog programming control by electrical signal or dry contact. Remote: 0~0.6V or short. Local: 2~30V or open.									
4. LOCAL/REMOTE Analog signal		---	analog programming control monitor signal. Open collector. Remote: On. Local: Off. Maximum Voltage: 30V, Maximum Sink Current: 10mA.									
5. ENABLE/DISABLE signal		---	Enable/Disable PS output by electrical signal or dry contact. 0~0.6V or short, 2~30V or open. User selectable logic.									
6. INTERLOCK (ILC) control		---	Enable/Disable PS output by electrical signal or dry contact. Remote: 0~0.6V or short. Local: 2~30V or open.									
7. Programmed signals		---	Two open drain programmable signals. Maximum voltage 25V, Maximum sink current 100mA (Shunted by 27V zener)									
8. TRIGGER IN / TRIGGER OUT signals		---	Maximum low level input voltage = 0.8V, Minimum high level input voltage = 2.5V, Maximum high level input = 5V positive edge trigger: tw=10us minimum. Tr, Tf=1us Maximum, Min delay between 2 pulses 1ms.									
9. DAISY_IN/SO control signal		---	By electrical Voltage: 0~0.6V/2~30V or dry contact.									
10. DAISY_OUT/PS_OK #2 signal		---	4~5V=OK, 0V (500ohm impedance)=Fail									
FUNCTIONS AND FEATURES												
1. Parallel operation		---	Possible. Up to 4 identical units in Master/Slave mode. Refer to instruction manual.									
2. Series operation		---	Possible. Two identical units. Refer to instruction manual.									
3. Daisy chain		---	Power supplies can be connected in Daisy chain to synchronize their turn-on and turn-off.									
4. Constant power control		---	Limits the output power to a programmed value. Programming via the communication ports or the front panel.									
5. Output resistance control		---	Emulates series resistance. Resistance range: 1~1000mΩ. Programming via the communication ports or the front panel.									
6. Slew rate control		---	Programmable Output rise and Output fall slew rate. Programming range: 0.0001~999.99 V/mSec. or A/mSec. Programming via the communication ports or the front panel.									
7. Arbitrary waveforms		---	Profiles of up to 100 steps can be stored in 4 memory cells. Activation by command via the communication ports or by the front panel.									
PROGRAMMING AND READBACK (USB, LAN, RS232/485, Optional IEEE (*18) Interfaces)		V	10	20	30	40	60	80	100	150	300	600
1.Vout programming accuracy (*15)		---	0.05% of rated output voltage									
2.Iout programming accuracy (*14)		---	0.1% of actual output current+0.2% of rated output current									
3.Vout programming resolution		---	0.002% of rated output voltage									
4.Iout programming resolution		---	0.0025% of rated output current									
5.Vout readback accuracy		---	0.05% of rated output voltage									
6.Iout readback accuracy (*14)		---	0.2% of rated output current									
7.Vout readback resolution (of rated output voltage)		%	0.011%	0.006%	0.004%	0.003%	0.002%	0.002%	0.011%	0.007%	0.004%	0.002%
8.Iout readback resolution (of rated output current)		%	0.01%	0.002%	0.003%	0.003%	0.005%	0.006%	0.007%	0.015%	0.003%	0.004%

GENESYS™ GH1kW/1.5kW SERIES SPECIFICATIONS

PROTECTIVE FUNCTIONS	V	10	20	30	40	60	80	100	150	300	600
1.Foldback protection	---	Output shut-down when power supply changes mode from CV or Power Limit to CC mode or from CC or Power Limit to CV mode. User presettable. Reset by AC input recycle in autostart mode, by Power Switch, by OUTPUT button, by rear panel or by communication.									
2.Over-voltage protection (OVP)	---	Output shut-down. Reset by AC input recycle in autostart mode, by OUTPUT button, by rear panel or by communication.									
3.Over-voltage programming range	V	0.5~12	1~24	2~36	2~44.1	5~66.15	5~88.2	5~110.25	5~165.37	5~330.75	5~661.5
4.Over-voltage programming accuracy	---	+/-1% of rated output voltage									
5.Output under voltage limit (UVL)	---	Prevents from adjusting Vout below limit. Does not apply in analog programming. Preset by front panel or communication port.									
6.Over temperature protection	---	Shuts down the output. Auto recovery by autostart mode.									
7. Output under voltage limit (UVL)	---	Prevents adjustment of Vout below limit.									
8. Output under voltage protection (UVP)	---	Prevents adjustment of Vout below limit. P.S output turns Off during under voltage condition. Reset by AC input recycle in autostart mode, by Power Switch, by OUTPUT button, by rear panel or by communication.									

FRONT PANEL		
1.Control functions	---	Multiple options with 2 Encoders
	---	Vout/Iout/Power Limit manual adjust
	---	OVP/UVL/UVP manual adjust
	---	Protection Functions - OVP, UVL, UVP, Foldback, OCL, ENA, ILC
	---	Communication Functions - Selection of LAN, IEEE, RS232, RS485, USB or Optional communication interface.
	---	Output ON/OFF. Front Panel Lock.
	---	Communication Functions - Selection of Baud Rate, Address, IP and communication language.
	---	Analog Control Functions - Selection Voltage/resistive programming, 5V/10V, 5K/10K programming
	---	Analog Monitor Functions - Selection of Voltage/Current Monitoring 5V/10V.
2.Display	---	Vout: 4 digits, accuracy: 0.05% of rated output voltage +/-1 count.
	---	Iout: 4 digits, accuracy: 0.2% of rated output current +/-1 count.
3.Front Panel Buttons Indications	---	OUTPUT ON, ALARM, PREVIEW, FINE, COMMUNICATION, PROTECTION, CONFIGURATION, SYSTEM, SEQUENCER.
4. Front Panel Display Indications	---	Voltage, Current, Power, CV, CC, CP, External Voltage, External Current, Address, LFP, Autostart, Safetstart, Foldback V/I, Remote (communication), RS/USB/LAN/IEEE communication, Trigger, Load/Store Cell.

ENVIRONMENTAL CONDITIONS		
1.Operating temperature	---	0~50°C, 100% load.
2.Storage temperature	---	-30~85°C
3.Operating humidity	%	20~90% RH (no condensation).
4.Storage humidity	%	10~95% RH (no condensation).
5.Altitude	---	Operating: 10000ft (3000m), output current derating 2%/100m or Ta derating 1°C/100m above 2000m. Non operating: 40000ft (12000m).

MECHANICAL		
1.Cooling	---	Forced air cooling by internal fans. Air flow direction: from Front panel to power supply rear
2.Weight	kg	Less than 3.5kg.
3.Dimensions (WxHxD)	mm	W: 214, H: 43.6, D: 432 (Without busbars and busbars cover), W: 214, H: 43.6, D: 493 (Including busbars and busbars cover) (Refer to Outline drawing).
4.Vibration	---	MIL-810G, method 514.6, Procedure I, test condition Annex C - 2.1.3.1
5.Shock	---	Less than 20G, half sine, 11mSec. Unit is unpacked.

SAFETY/EMC			
1.Applicable standards:	Safety GH1kW/1.5kW	---	UL61010-1, CSA22.2 No. 61010-1, IEC61010-1, EN61010-1.
1.1. Interface classification	GH1kW/1.5kW	---	Vout < 40V Models: Output, J1, J2, J3, J4, J5, J6, J7, J8 (sense) and J9 (communication options) are SELV. 60 ≤ Vouts < 600V Models: Output, J8 (sense) are hazardous, J1, J2, J3, J4, J5, J6, J7 and J9 (communication options) are SELV
1.2 Withstand voltage	GH1kW/1.5kW	---	Vout < 40V Models: Input - Output (SELV): 4242VDC 1min, Input - Ground: 2835VDC 1min. 60V ≤ Vouts < 100V Models: Input - Output: 4242VDC 1min, Input - SELV: 4242VDC 1min, Output - SELV: 850VDC 1min, Output - Ground: 1500VDC 1min, Input - Ground: 2835VDC 1min. 100 < Vouts < 600V Models: Input - Output: 4242VDC 1min, Input - SELV: 4242VDC 1min, Output - SELV: 1275VDC 1min, Output - Ground: 2500VDC 1min, Input - Ground: 2835VDC 1min.
1.3 Insulation resistance		---	100Mohm at 25°C, 70%RH. Output to Ground 500VDC
2.Conducted emission		---	IEC/EN61204-3 Industrial environment, Annex H table H.1, FCC Part 15-A, VCCI-A.
3.Radiated emission		---	IEC/EN61204-3 Industrial environment, Annex H table H.3 and H4, FCC Part 15-A, VCCI-A
4. EMC compliance	EMC (*4)	---	IEC/EN61204-3 Industrial environment

Unless otherwise noted, specifications are warranted over the ambient temperature range of 0° to 50°C

NOTES:

- *1: Minimum voltage is guaranteed to maximum 0.1% of rated output voltage.
- *2: Minimum current is guaranteed to maximum 0.2% of rated output current.
- *3: For cases where conformance to various safety standards (UL, IEC, etc...) is required, to be described as 100-240Vac (50/60Hz).
- *4: Signal and control ports interface cables length: Less than 3m, DC output power port cables length: Less than 30m.
- *5: Not including EMI filter inrush current, less than 0.2mSec.
- *6: 85~132Vac or 170~265Vac. Constant load.
- *7: From No-Load to Full-Load, constant input voltage. Measured at the sensing point in Remote Sense.
- *8: For 10V~300V models: Measured with JEITA RC-9131C (1:1) probe. For 400~600V model: Measured with 100:1 probe.
- *9: For load voltage change, equal to the unit voltage rating, constant input voltage.
- *10: The maximum voltage on the power supply terminals must not exceed the rated voltage.
- *11: From 10% to 90% of Rated Output Voltage, with rated, resistive load.
- *12: From 90% to 10% of Rated Output Voltage.
- *13: For 10V model, the ripple is measured at 20~100% of rated output voltage and rated output current. For other models, the ripple is measured at 10~100% of rated output voltage and rated output current. B.W 5Hz~1MHz.
- *14: The Constant Current programming, readback and monitoring accuracy do not include the warm-up and Load regulation thermal drift.
- *15: Measured at the sensing point.
- *16 Max. ambient temperature for using IEEE is 40°C.
- *17: Ta=25°C, rated output power.

Outline Drawing **GENESYS™** GH1kW (10V-100V)

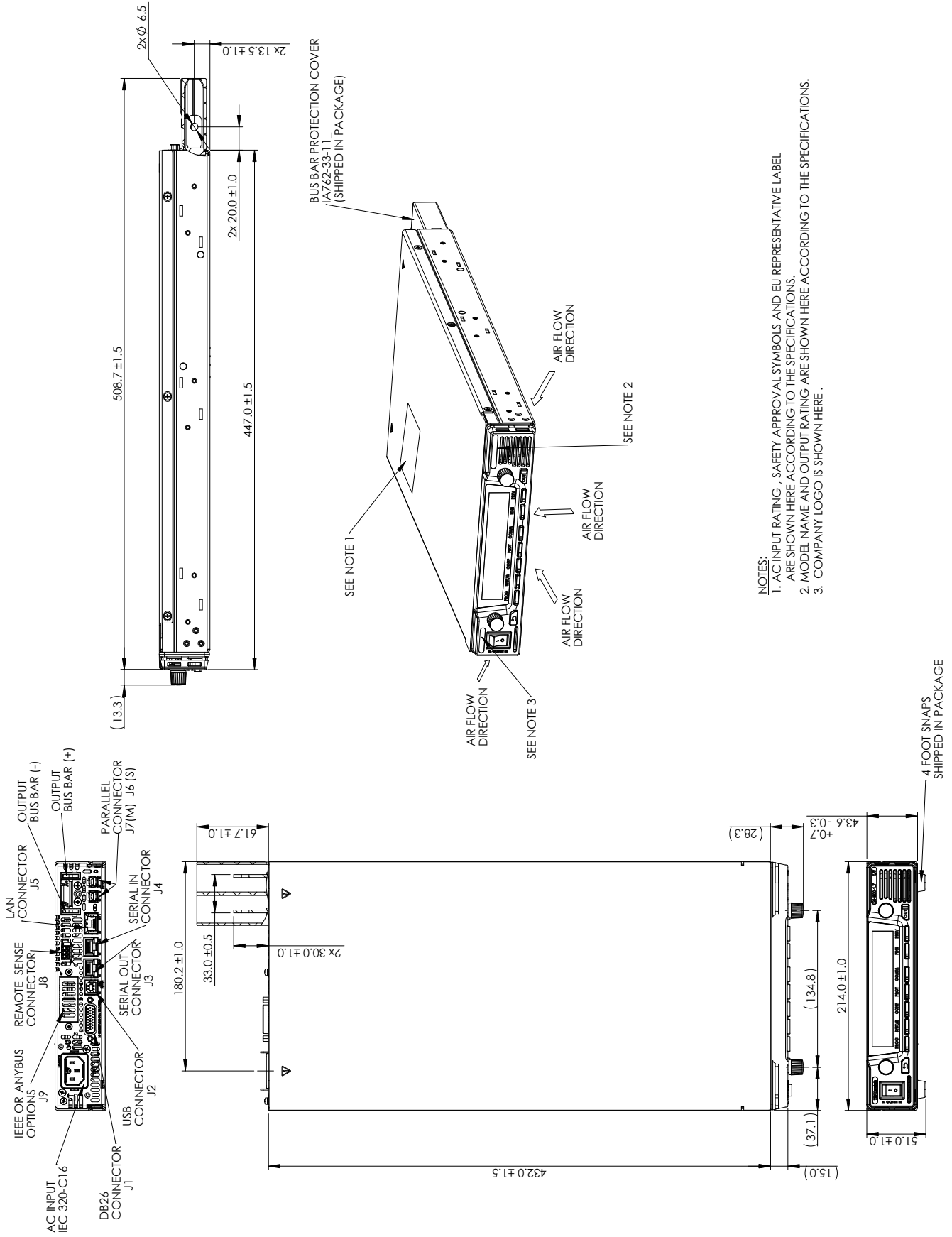

- NOTES:
1. AC INPUT RATING, SAFETY APPROVAL SYMBOLS AND EU REPRESENTATIVE LABEL ARE SHOWN HERE ACCORDING TO THE SPECIFICATIONS.
 2. MODEL NAME AND OUTPUT RATING ARE SHOWN HERE ACCORDING TO THE SPECIFICATIONS.
 3. COMPANY LOGO IS SHOWN HERE.

Outline Drawing **GENESYS™** GH1kW (150V-600V)

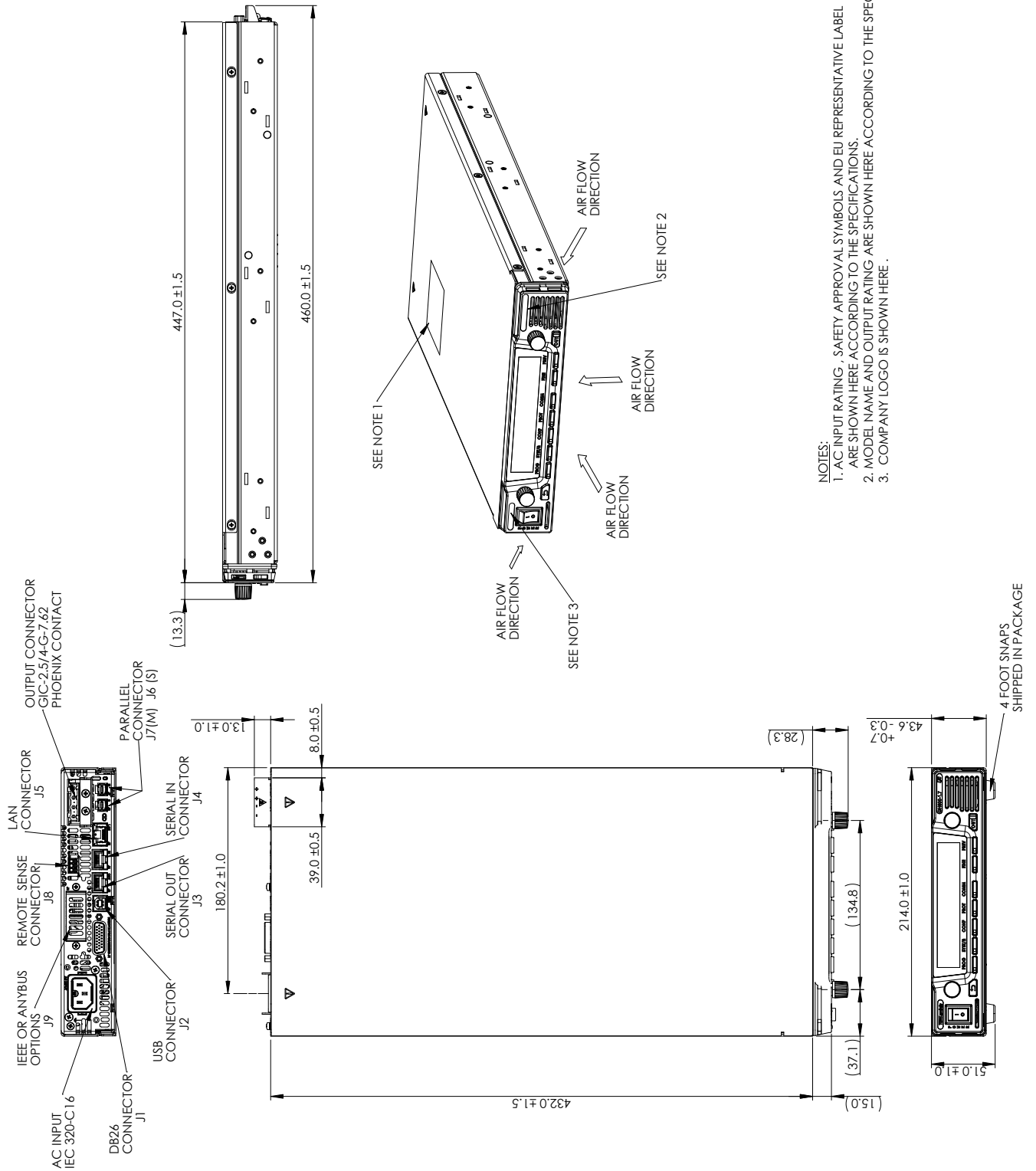

NOTES:
 1. AC INPUT RATING, SAFETY APPROVAL SYMBOLS AND EU REPRESENTATIVE LABEL ARE SHOWN HERE ACCORDING TO THE SPECIFICATIONS.
 2. MODEL NAME AND OUTPUT RATING ARE SHOWN HERE ACCORDING TO THE SPECIFICATIONS.
 3. COMPANY LOGO IS SHOWN HERE.

Outline Drawing **GENESYS™** GHB1kW

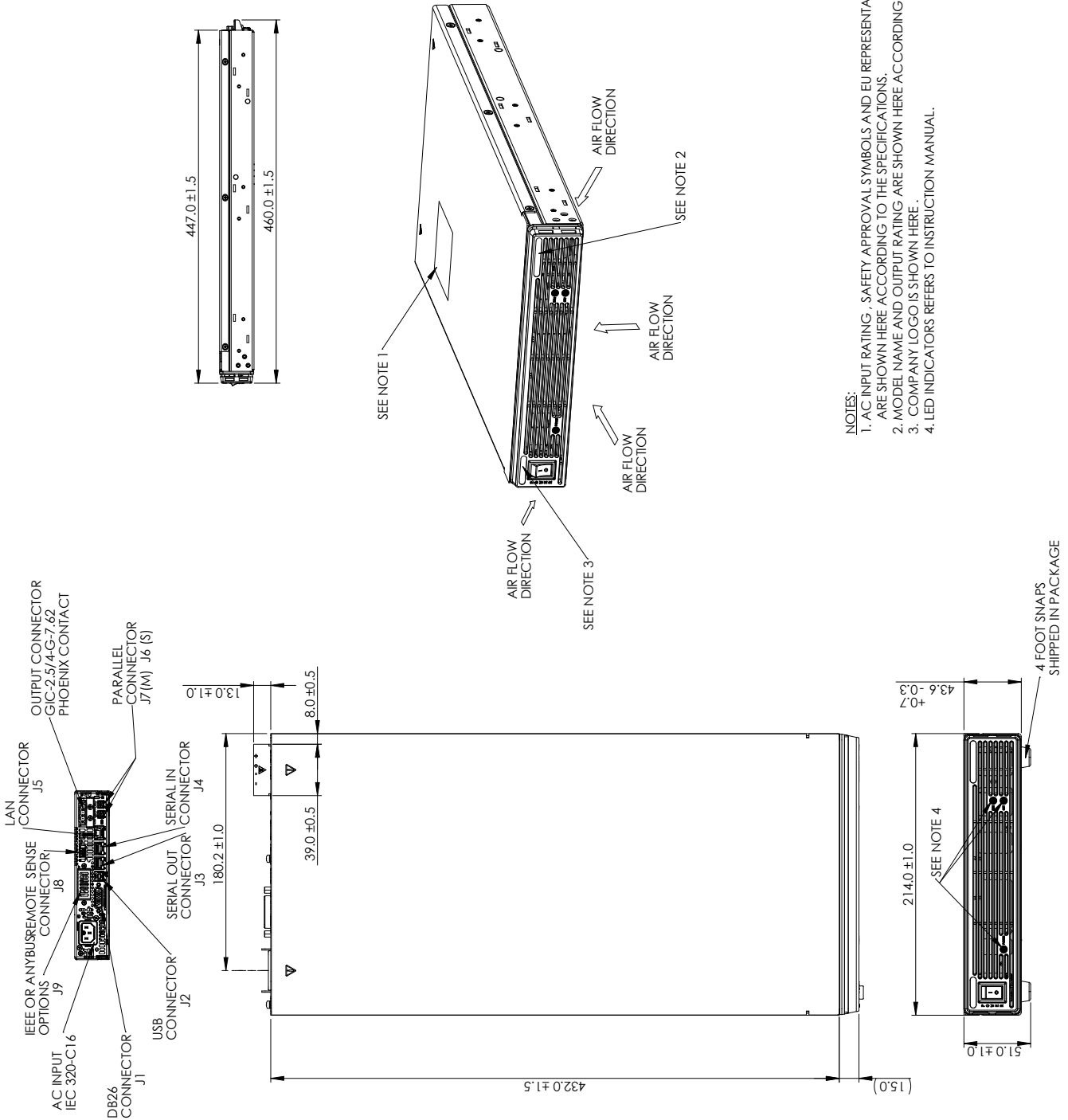

- NOTES:
1. AC INPUT RATING, SAFETY APPROVAL SYMBOLS AND EU REPRESENTATIVE LABEL ARE SHOWN HERE ACCORDING TO THE SPECIFICATIONS.
 2. MODEL NAME AND OUTPUT RATING ARE SHOWN HERE ACCORDING TO THE SPECIFICATIONS.
 3. COMPANY LOGO IS SHOWN HERE.
 4. LED INDICATORS REFERS TO INSTRUCTION MANUAL.

Outline Drawing **GENESYS™** GH1.5kW (10V-100V)

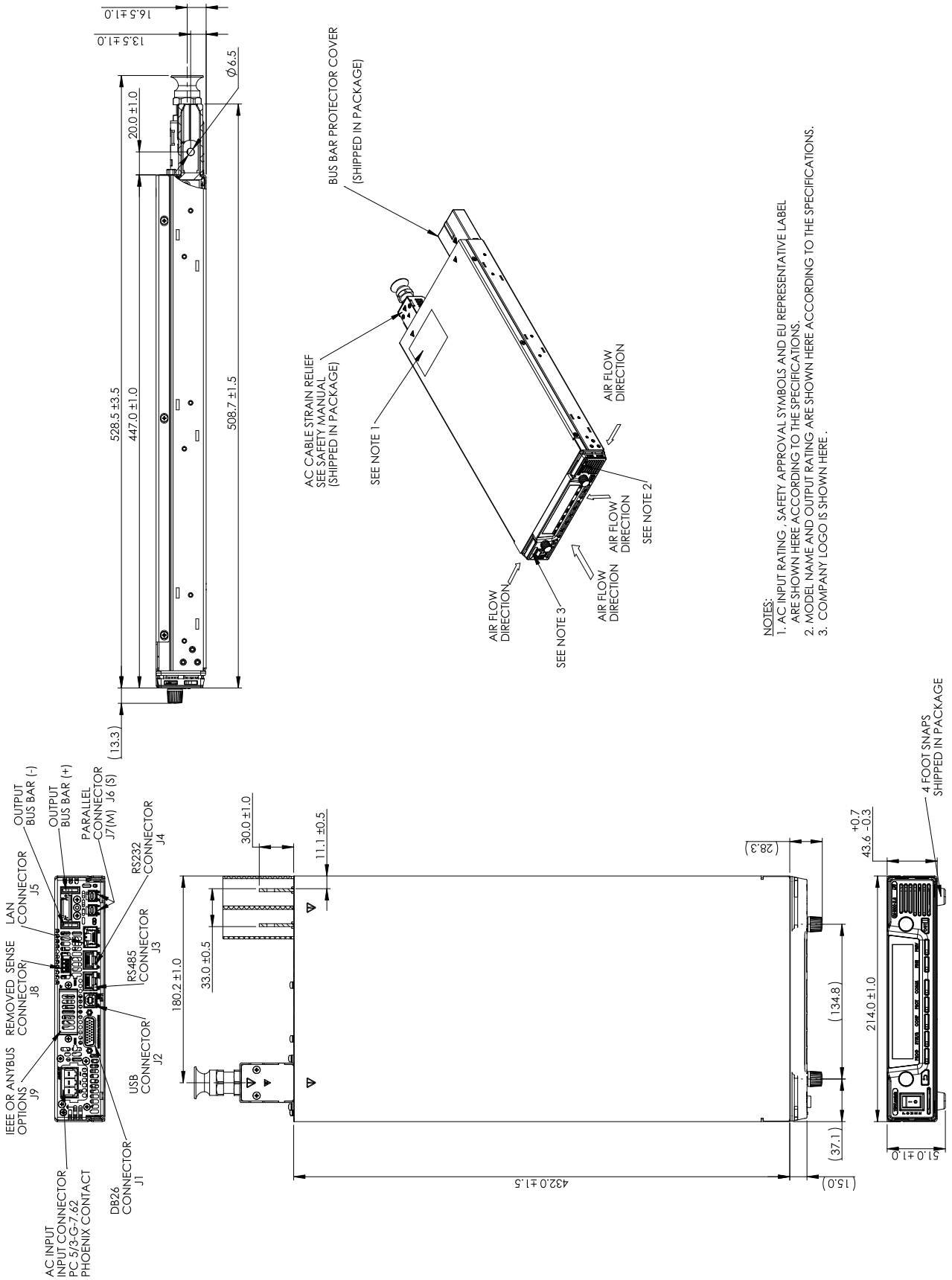

NOTES:
 1. AC INPUT RATING, SAFETY APPROVAL SYMBOLS AND EU REPRESENTATIVE LABEL ARE SHOWN HERE ACCORDING TO THE SPECIFICATIONS.
 2. MODEL NAME AND OUTPUT RATING ARE SHOWN HERE ACCORDING TO THE SPECIFICATIONS.
 3. COMPANY LOGO IS SHOWN HERE.

Outline Drawing **GENESYS™** GH1.5kW (150V-600V)

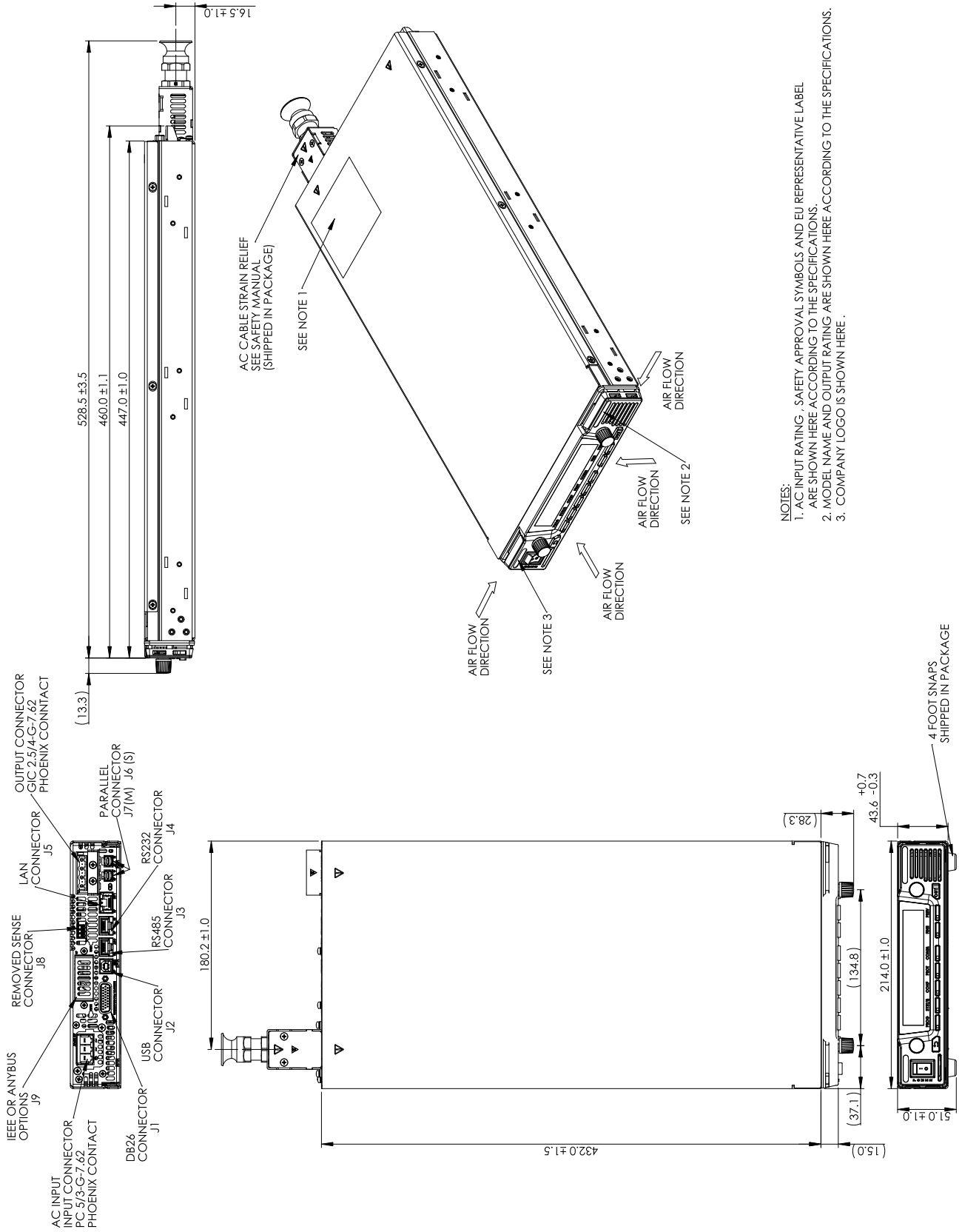

- NOTES:
1. AC INPUT RATING, SAFETY APPROVAL SYMBOLS AND EU REPRESENTATIVE LABEL ARE SHOWN HERE ACCORDING TO THE SPECIFICATIONS.
 2. MODEL NAME AND OUTPUT RATING ARE SHOWN HERE ACCORDING TO THE SPECIFICATIONS.
 3. COMPANY LOGO IS SHOWN HERE.

Outline Drawing **GENESYS™** GHB1.5kW

ROHS COMPLIANCE

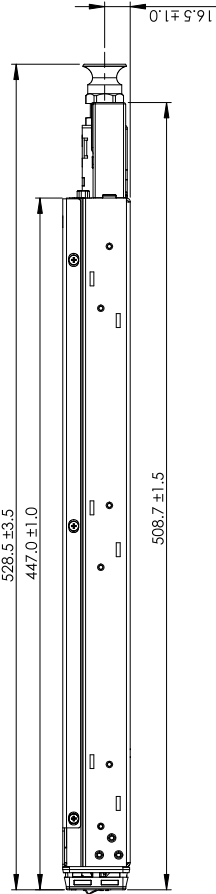
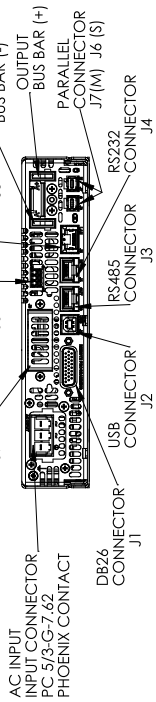

BUS BAR PROTECTOR COVER (SHIPPED IN PACKAGE)
 AC CABLE STRAIN RELIEF SEE SAFETY MANUAL (SHIPPED IN PACKAGE)
 SEE NOTE 1

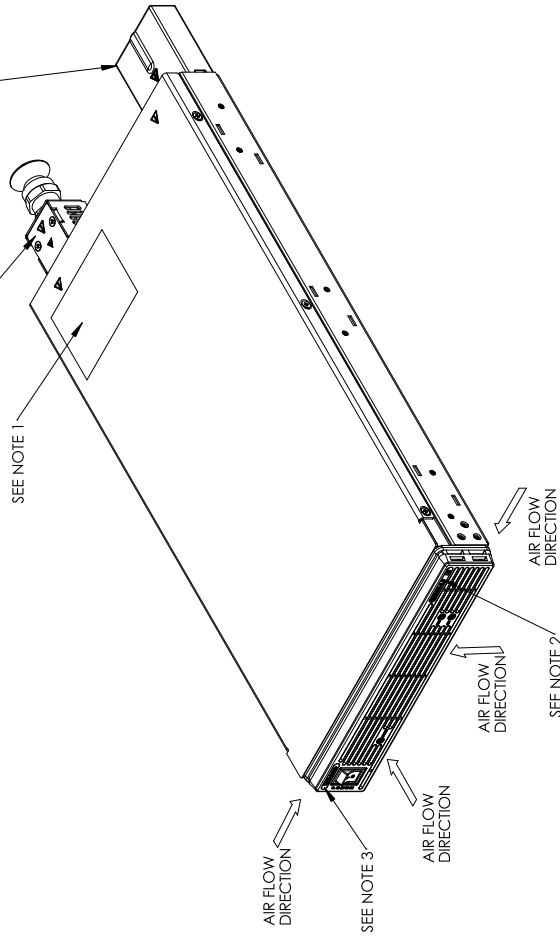

- NOTES:
 1. AC INPUT RATING, SAFETY APPROVAL SYMBOLS AND EU REPRESENTATIVE LABEL ARE SHOWN HERE ACCORDING TO THE SPECIFICATIONS.
 2. MODEL NAME AND OUTPUT RATING ARE SHOWN HERE ACCORDING TO THE SPECIFICATIONS.
 3. COMPANY LOGO IS SHOWN HERE.

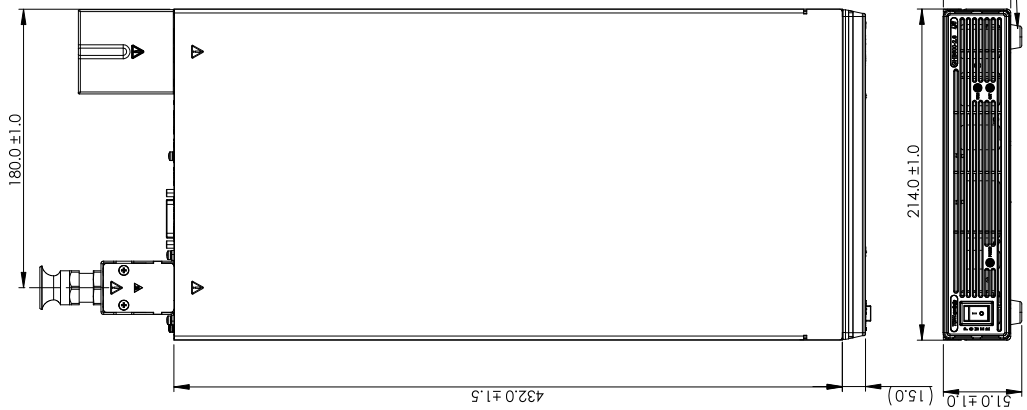

NORTH AMERICA

TDK-Lambda Americas Inc
405 Essex Rd. Neptune, NJ 07753
Tel: +1-732-922-9300 Fax: +1-732-922-1441
E-mail: sales@us.tdk-lambda.com
www.us.lambda.tdk.com

UK

TDK-Lambda UK Ltd.
Kingsley Avenue Ilfracombe, Devon
EX 34 8ES, United Kingdom
Tel: +44-1271-856666 Fax: +44-1271-864894
E-mail: info@uk.tdk-lambda.com
www.emea.lambda.tdk.com/uk

FRANCE

TDK-Lambda France SAS
3 Avenue du Canada,
Parc Technopolis - Bâtiment Sigma,
91940 Les Ulis - France CS 41077
Tel: +33 1 60 12 71 65 Fax: +33 1 60 12 71 66
E-mail: france@fr.tdk-lambda.com
www.emea.lambda.tdk.com/fr

GERMANY

TDK-Lambda Germany GmbH
Karl-Bold-Str.40,
D-77855 Achern, Germany
Tel: +49-7841-666-0 Fax: +49-7841-500-0
E-mail: info.germany@de.tdk-lambda.com
www.emea.lambda.tdk.com/de

AUSTRIA

TDK-Lambda Germany GmbH Austria Sales Office
Aredstrasse 22, 2544 Leobersdorf, Austria
Tel: +43-2256-65584 Fax: +43-2256-64512
E-mail: info@at.tdk-lambda.com
www.emea.lambda.tdk.com/at

ITALY

TDK-Lambda France Sas Succursale Italiana
Via Giacomo Matteotti 62,
20092 Cinisello Balsamo (MI), Italia
Tel: +39-02-6129-3863 Fax: +39-02-6129-0900
E-mail: info.italia@it.tdk-lambda.com
www.emea.lambda.tdk.com/it

ISRAEL

TDK-Lambda Ltd.
Sales Office: Alexander Yanai 1, Petah Tikva, 4927701, ISRAEL
Tel: +972-3-9024-333 Fax: +972-3-9024-777
Plant: 56 Haharoshet St.,
Karmiel Industrial Zone 2165158, Israel
Tel: +972-4-9887-491 Fax: +972-4-9583-071
www.emea.lambda.tdk.com/il E-mail: info@tdk-lambda.co.il

Switzerland

TDK-Lambda Germany GmbH
Switzerland Sales Office, Eichtalstr. 55
8634 Hombrechtikon - Switzerland
Tel: +41 44 850 53 53
E-mail: info@ch.tdk-lambda.com
www.emea.lambda.tdk.com/ch

Denmark

TDK-Lambda Nordic
Haderslevvej 36B, DK-6000 Kolding, Denmark
TEL: +45-8853-8086
E-mail: info@dk.tdk-lambda.com
www.emea.lambda.tdk.com/dk

JAPAN

TDK-Lambda Corporation
Nihonbashi Takashimaya Mitsui Bldg. 2-5-1 Nihonbashi,
Chuo-ku, Tokyo 103-6128, JAPAN
TEL: +81-3-6778-1113 FAX: +81-3-6778-1160
www.jp.lambda.tdk.com

CHINA

TDK-Lambda (China) Electronics Co. Ltd,
Shanghai Office 5th Floor Kehui Tower, 1188 Qinzhou Road (North),
Xuhui District Shanghai 200233, China
Tel: +86-21-6485-0777 Fax: +86-21-6485-0666
www.lambda.tdk.com.cn

Beijing Branch of TDK-Lambda (China) Electronic Co. Ltd.
Room 12B11-12B12, Unit 7 Dacheng square, No.28
Xuanwumenxi Street, Xuanwu District Beijing, 100053, CHINA
Tel: +86-10-6310-4872 Fax: +86-10-6310-4874
www.lambda.tdk.com.cn

Shenzhen Branch of TDK-Lambda (China) Electronics Co.Ltd.
69/F, Ping An Finance Centre, 5033 Yitian Road,
Futian District, Shenzhen, China
Tel: +86-755-83588261 Fax: +86-755-83588260
www.lambda.tdk.com.cn

KOREA

TDK-Lambda Corporation Korea Branch
Seocho-Dong, 12F. Songnam Bldg. 273, Gangnam Daero,
Seocho-Gu, Seoul 06730, Republic of Korea
Tel: +82-2-3473-7051 Fax: +82-2-3472-9137
www.lambda.tdk.co.kr

SINGAPORE

TDK-Lambda Singapore Pte.Ltd.
Blk 1008 Toa Payoh North # 07-01/03
Singapore 318996
Tel: +65-6251-7211 Fax: +65-6250-9171
www.sg.lambda.tdk.com

INDIA

TDK India Private Limited. Power Supply Division
#87, The Centrum, 4th Floor, Infantry Road, Bengaluru,
Karnataka, -560 001, INDIA
Tel: +91-80-40390660 Fax: +91-80-40390603

MALAYSIA

TDK-Lambda Malaysia Sdn. Bhd. (Nilai Office)
c/o TDK (Malaysia) Sdn. Bhd., Lot 709, Nilai Industrial Estate
71800 Nilai, Negeri Sembilan, MALAYSIA
TEL: +60-6-797-8800 Fax: +60-6-797-8966



TDK-Lambda

Innovating Reliable Power

GLOBAL NETWORK

TDK-Lambda EMEA
www.emea.lambda.tdk.com